

S30

The Classical
for medium-sized precision components.



Key data

The S30 is a cylindrical grinding machine for medium-sized workpieces in individual and small batch production.

It has distances between centres of 650/1000 mm and centre heights of 125/175/225 mm.

It can machine workpieces with a maximum weight of 130 kg.



The Art of Grinding.

Fritz Studer AG

The name STUDER stands for more than 100 years of experience in the development and production of precision cylindrical grinding machines. «The Art of Grinding.» is our passion, highest precision is our aim and top Swiss quality is our benchmark.

Our product line includes both standard machines, as well as complex system solutions in high-precision cylindrical grinding for machining small and medium-sized workpieces. In addition we offer software, system integration and a wide range of services. As well as receiving a complete tailor-made solution the customer also benefits from our 100 years of know-how in relation to the grinding process.

Our customers include companies from the machine tool industry, automotive engineering, tool and die makers, the aerospace industry, pneumatics/hydraulics, electronics/electrical engineering, medical technology, the watch industry and job order production. They value maximum precision, safety, productivity and longevity. 22 000 manufactured and delivered systems make us the market leader and are clear evidence of our technological leadership in universal, external, internal and noncircular grinding. Around 800 employees, including 75 apprentices, make it their goal every day to ensure that «The Art of Grinding.» will continue to be closely linked to the name STUDER in the future.

S30

If you want to have everything under control with just one lever, then the S30 was made for you. This simple and low-cost machine will allow you to produce precise, medium-sized parts. Thanks to its hydraulic control system the S30 is very easy to operate, so that the expert can give his full attention to the grinding process. Automatic grinding cycles guarantee high productivity with consistent quality.

Characteristics

Dimensions

- Distance between centres 650/1 000 mm (25.6" / 39.4")
- Height of centres 125/175/225 mm (4.9" / 6.9" / 8.9")
- Max. workpiece weight 130 kg (286 lbs)

Features

- Optional wheelhead:
 - Turret wheelhead with grinding wheel on the left and right, plus internal grinding attachment (optional) with 5 deg manual Hirth swivel to a stop of 0 deg and 180 deg
 - External wheelhead with grinding wheel on the left
- Table can be swivelled 10 deg/8.5 deg



- Workhead fitted with hydrodynamic bearing as standard and a roller-bearing workhead (optional) make it possible to grind between fixed centres as well as with rotating centres
- Tailstock with adjustable centre pressure and fine adjustment for quick and easy cylindricity correction
- Control cabinet permanently attached to the machine. Can be expanded for in-process gauging and Sensitron.
- Granitan® S103 mineral-cast machine base
- Automatic grinding cycle with automatic cut-out:
 - Rapid infeed
 - Grinding feed 1 and 2
 - Spark-out
- Rapid retraction of the feed handwheel to the preset grinding allowance
- Plunge grinding and travel grinding with or without rapid infeed
- External and internal grinding possible in one clamping
- Extensive range of accessories



The Universal Cylindrical Grinding Machine with hydraulic drives for the production of medium-sized workpieces.

The S30 is designed for the grinding of workpieces in single-component or small series production. It is suitable for any sector in which medium-sized components are produced. This simple, reasonably priced machine has a tried-and-tested hydraulic infeed system. It is very easy to operate and can be set up extremely quickly. This proven concept enables the specialist to devote his full concentration to the grinding process.

The Granitan® S103 machine bed provides the basis for the fitting of technologically outstanding components to form a cylindrical grinding machine guaranteeing the highest possible precision, performance and reliability levels for many years.

The efficient automatic grinding cycles with automatic cut-out are controlled hydraulically, as are all the axes. Features such as rapid infeed, grinding feed, spark-out, rapid retraction of the handwheel to the preset grinding allowance plus the cycles for plunge and traverse grinding are unique and form part of the basic equipment.

The systematic development, production, assembly and testing of our products are carried out in a process-oriented manner. They comply with the stringent VDA6.4 and ISO 9001 norms.

Wheelhead

1



- Flexible
- Compact
- Internal grinding attachment

There is a choice of two variations for universal applications for external, surface and internal grinding:

- Turret wheelhead for external and internal grinding with an external grinding wheel on the right and left and one internal grinding spindle. High-precision manual indexing (5 deg) is possible using a Hirth gear within a swivel range of 0 deg to +180 deg.
- External wheelhead on the left: external grinding with wheel on the left

Grinding spindle bearing

The hydrodynamic plain bearing of the external grinding spindle guarantees many years of high run-out with minimal maintenance. It is wear-free with no clearance adjustment and low maintenance.

Internal grinding spindles

Belt-driven spindles can be used for the internal grinding attachment. The belt-driven internal grinding spindle is equipped with an oil mist lubrication device.

Nominal rpm

20 000, 40 000 and 60 000 min⁻¹.

External and internal grinding is possible in one clamping.

2

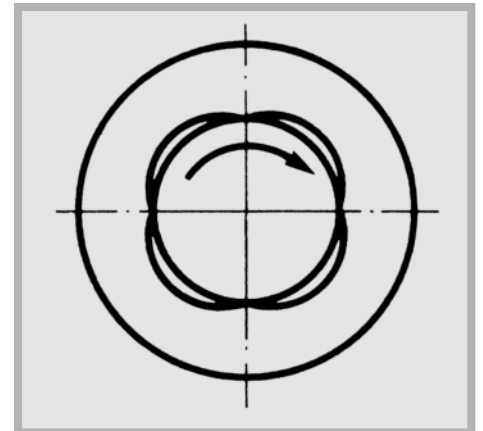

3



- 1 Wheelhead
- 2 Hydrodynamic plain bearing
- 3 Internal grinding attachment (optional)

Workhead

1



The swivelling workhead with hydrodynamic bearing makes it possible to grind between fixed centres as well as with rotating centres. The powerful workhead spindle, relieved from belt tension, rotates in a hydrodynamic multi-surface plain bearing. Roundness during live spindle grinding is 0.0003 mm (0.000,012"), with the option of 0.0001 mm (0.000,004") available. The workhead is driven by a stepped AC motor.

- Frequency converter for infinitely variable speed control (optional)
- A workhead with swivelling roller bearing is available as an option

- High roundness levels
- Low maintenance
- Grinding between centres and live spindle grinding

Tailstock

2



3



The rigid tailstock has a generously dimensioned barrel for holding Morse 3 centres. The barrel glides in covered plain bearings, and the centre pressure can be finely adjusted. The fine adjustment enables quick and easy cylindricity correction (optional), as required for the machining of high-precision workpieces.

- The tailstock can be fitted with hydraulic barrel retraction and an adjustable dressing device

Granitan[®] S103 mineral-casting machine base

1



- Vibration-damping
- Thermal stability
- Non-wearing

The material structure developed by STUDER and which has proved its superb efficiency over many years is produced in the company's own plant using the most modern industrial techniques.

- The excellent dampening proprieties of the machine base ensures outstanding surface quality of the ground workpieces. The service life of the grinding wheel is also increased, leading to reduced downtimes.
- Temporary temperature fluctuations are extensively compensated for by the favorable thermal behavior of Granitan[®], resulting in high dimensional accuracy at all times.
- The V and flat guideways for the longitudinal and cross slides are moulded directly into the machine base and are provided with a non-abrasive Granitan[®] S200 slideway coating. The patented knobbed structure of the guideways largely eliminates the slip-stick effect or floating of the slides observed on conventional guideways. The guideways offer the highest possible accuracy through the entire speed range with high load capacity and dampening levels. Thanks to the robust and maintenance-free design, these excellent guideway characteristics are more or less completely retained.

2

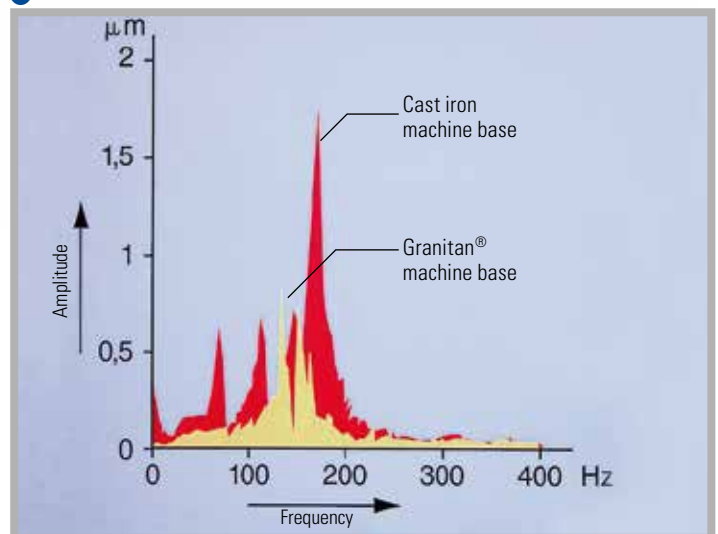

3



- 1 Machine base with longitudinal and cross guides
- 2 Vibration behaviour of grey cast iron and Granitan[®] S103
- 3 Guideways with patented surface structure

Longitudinal and cross slides

1

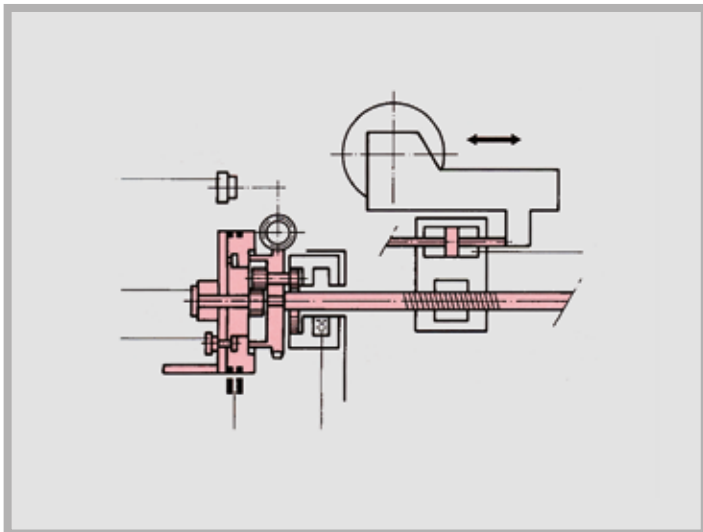

2

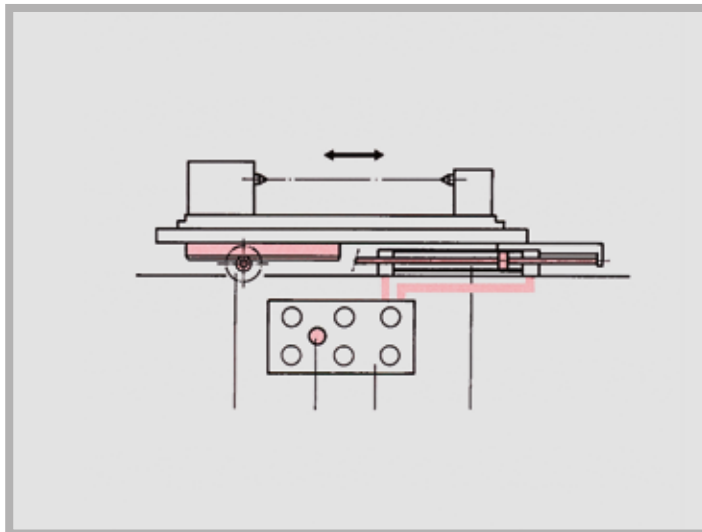

3

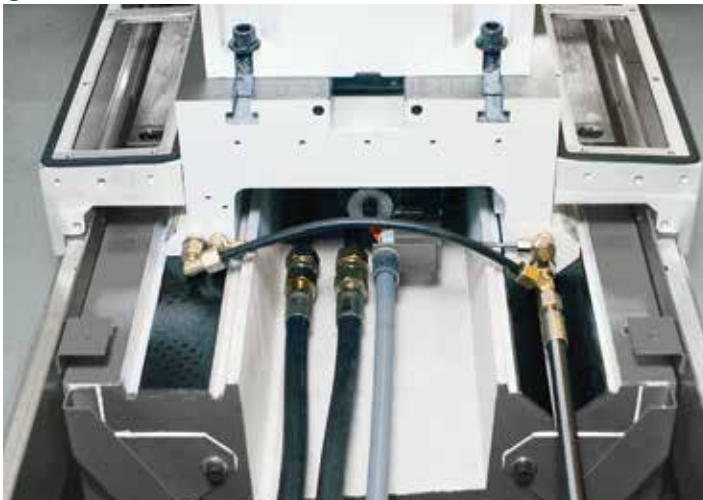

- Low coefficient of friction
- Hydraulic rapid approach
- No-play feed system
- Low wear
- Repeatable accuracy

The longitudinal and cross slides are manufactured from high-quality gray cast iron and have highly precise, ground V and flat guideways, with the distance between the guideways optimally suited to the machine's overall rigidity. The slides rest completely on the guideways of the machine bed through the entire speed range. This provides the cornerstone for the excellent inherent grinding straightness of 0.0025 mm (0.000,10") over 610 mm (24") measured length.

Longitudinal slide on the Z axis

The longitudinal slide with swivelling table is driven manually via the handwheel or automatically via hydraulic cylinders with infinitely variable speed control. The quick-reacting hydraulics with soft and very precise conversions ensure high precision during rapid speed changes. Optional: fine adjustment plus air lift to the swivelling table for rapid cylindricity corrections and precise setting of taper angles. Digital display of the position of the longitudinal slide.

Cross slide on the X axis

The drive is via a handwheel or automatically via a rolling ball spindle and hydraulic motor. The mechanics of the wheelhead axis include a fine adjustment device, enabling infeed corrections in the range of fractions of a micrometre. Optional: Sensitron contact control unit, OD gauge, digital cross slide position display.

- 1 Illustration of the wheelhead axis
- 2 Illustration of the longitudinal axis
- 3 V and flat guideway (cross slide)

Machine control and operation



- Control cabinet EMV-tested
- Ergonomically arranged controls

The control cabinet is permanently attached to the machine, making it ready for operation immediately. The control is reliable and maintenance-free. The electrical equipment complies with the relevant safety norms and is EMV-tested. A clear device layout ensures optimum ease of operation.

Automatic grinding cycle with automatic cut-out:

- Rapid infeed
- Grinding feed
- Spark-out
- Rapid retraction of the feed handwheel to the preset grinding allowance

Grinding programs:

- Plunge grinding with short longitudinal slide stroke or travel grinding with continuous infeed
- Travel grinding with intermittent infeed on the left, right or both ends of the stroke

The Sensitron contact control unit including vibration pick-up provides for automatic switch-over of infeed to grinding feed.

This contact detection enables the machine to achieve touching speeds of 0,06 – 30 mm/min (0.002 – 1.18 ipm). This option reduces grinding and setup times to a minimum.

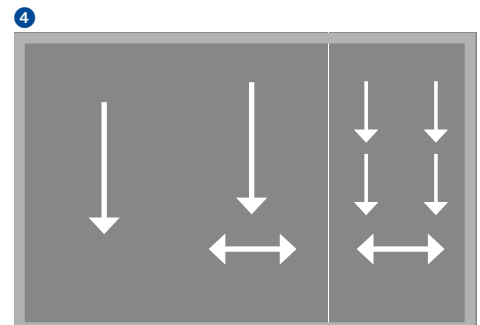
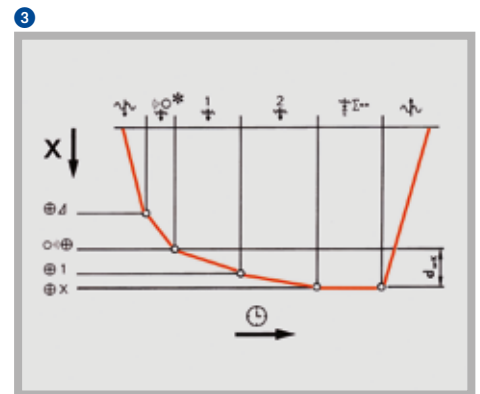

1 Position display
2 Control panel with possibility of fitting a contact control unit and in-process gauging unit

3 Illustration of the grinding feed
4 Infeed movement of the grinding programs

Customer Care

STUDER cylindrical grinding machines should fulfil the customer's requirements for as long as possible, work cost-effectively, function reliably and be available at all times. From «start up» through to «retrofit» – our Customer Care is there for you throughout the working life of your machine. 30 professional helplines and more than 60 service technicians are available in your area, wherever you are in the world.

- We will provide you with fast, uncomplicated support.
- We will help to increase your productivity.
- We work professionally, reliably and transparently.
- We will provide a professional solution to your problems.



Start up

Commissioning
Warranty extension



Qualification

Training
Production support



Prevention

Maintenance
Inspection



Service

Customer service
Customer consultation
HelpLine
Remote service

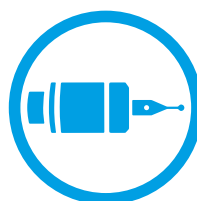

Material

Spare parts
Replacement parts
Accessories



Rebuilt

Machine overhaul
Assembly overhaul



Retrofit

Modifications
Retrofits

Technical Data

Main dimensions

Distance between centres	650/1 000 mm (25.6"/39.4")
Height of centres	125/175/225 mm (4.9"/6.9"/8.9")
Max. workpiece weight between centres	130 kg (286 lbs)

Cross slide: X axis

Rapid infeed	60 mm (2.36")
Max. travel	255 mm (10.2")
	[plunge depth 3,4 mm (0.134")]
Speed	0,012–6 mm/min (0.000,5–0.24 ipm)
Incremental feed	0,001–0,05 mm (0.000,04–0.002")
Spark-out time	0–6 s
Handwheel rotation	4 mm (0.16")/dia.

Longitudinal slide: Z axis

Max. travel	700/1 050 mm (27.5"/41.3")
Speed	50–5 000 mm/min (1.97–197 ipm)
Reverse delay	0–6 s
Minimum automatic table travel	1,5 mm (0.06")
Reverse precision at constant speed	0,02 mm (0.000,8")
Machine table swivel range	10 deg/8,5 deg

Wheelhead

Swivel range	0 deg to +180 deg
Fitting taper	dia. 63 mm (2.5")
Driving power	5,5 kW (7.5 hp)
Speeds	1 670/2 110 rpm
Grinding wheel left, dia. x width x bore	400 x 63 (80F5) x 127 mm (dia. 500 mm Option) [16" x 2.5" (80F5) x 5"]
Grinding wheel right, dia. x width x bore	400 x 40 x 127 mm [16" x 1.6" x 5"]
Circumferential speed	35 m/s (6888 sfpm) to 50 m/s (9840 sfpm)
Internal grinding spindle for belt-driven spindles	optional
Adaption bore	100 mm (3.94")

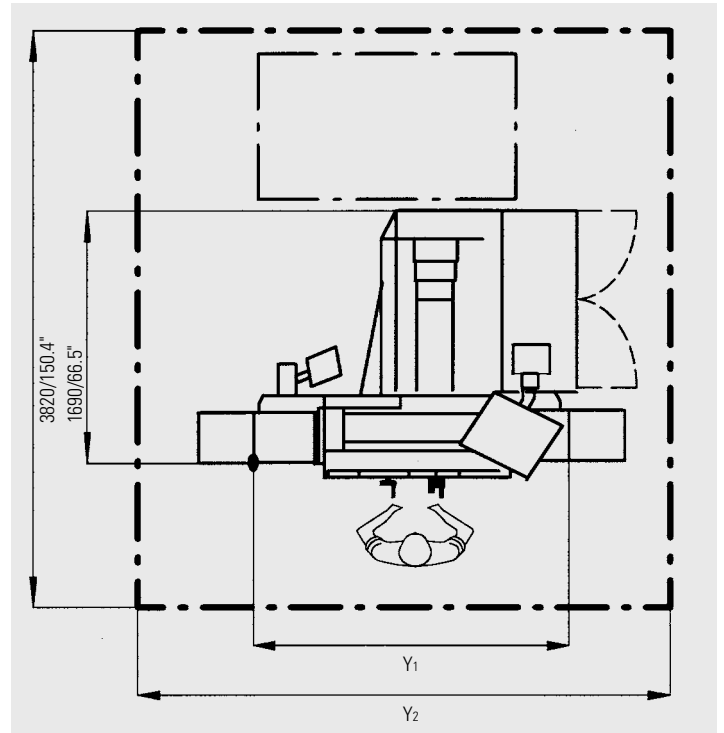

Distances between centres

	Y1	Y2
650 mm	2035/80,1"	3500/137,8"
1000 mm	2735/107,7"	3900/153,5"

The information given is based on the technical levels of our machine at the time of this brochure going to print. We reserve the right to further develop our machines technically and make design modifications. This means that the dimensions, weights, colours, etc. of the machines supplied can differ. The diverse application possibilities of our machines depend on the technical equipment specifically requested by our customers. The equipment specifically agreed with the customer is therefore exclusively definitive for the equipping of the machines, and not any general data, information or illustrations.

Workhead swivelling

hydrodynamic bearing

roller bearing

Speed range	30–1 000 rpm	35/90/210/520 rpm
Fitting taper	MT 5	MT 5
Bar capacity	dia. 30 mm (1.2")	dia. 38 mm (1.4")
Driving power	0,55 kW	0,55 kW
Load during live grinding	100 Nm (74 ft lbs)	100 Nm (74 ft lbs)
Roundness accuracy during live grinding	0,0003/0,0002/0,0001 mm (0.000,012" / 0.000,008" / 0.000,004")	0,0005 mm (0.000,02")

Tailstock

Fitting taper	MT 3
Barrel stroke	35 mm (1.37")
Barrel diameter	50 mm (1.97")
Fine adjustment for cylindricity corrections	±40 µm (0.0016")

Control

Hydraulic infeed system

Guaranteed working precision

Gauge length 610 mm (24")	0,0025 mm (0.000,10")
Gauge length 950 mm (37.4")	0,003 mm (0.000,12")

Connected loads

Total connected load	13 kVA
Air pressure	5 bar (73 psi)

Total weight

Distance between centres 650 mm	3 400 kg (7 480 lbs)
Distance between centres 1 000 mm	3 500 kg (7 700 lbs)



Fritz Studer AG
CH-3602 Thun
Phone +41 33 439 11 11
Fax +41 33 439 11 12
info@studer.com
www.studer.com



ISO 9001
VDA6.4
certified

